

USER'S MANUAL

OV / OVK / VKF / OVP / OV1 / OVK1 / OV1 R / VKOM(z) / VKOM1(z)



Electric axial fans

CONTENTS

Safety requirements.....	2
Purpose.....	4
Delivery set.....	4
Designation key.....	5
Technical data.....	5
Unit design and operating principle.....	10
Mounting and set-up.....	11
Connection to power mains.....	16
Technical maintenance.....	19
Troubleshooting.....	21
Storage and transportation regulations.....	21
Manufacturer's warranty.....	22
Certificate of acceptance.....	23
Seller information.....	23
Installation certificate.....	23
Warranty card.....	23

This user's manual is a main operating document intended for technical, maintenance, and operating staff.

The manual contains information about purpose, technical details, operating principle, design, and installation of the OV / OVK / VKF / OVP / OV1 / OVK1 / OV1 R / VKOM(z) / VKOM1(z) unit and all its modifications.

Technical and maintenance staff must have theoretical and practical training in the field of ventilation systems and should be able to work in accordance with workplace safety rules as well as construction norms and standards applicable in the territory of the country.

SAFETY REQUIREMENTS

Connection to the mains must be made through a disconnecting device, which is integrated into the fixed wiring system in accordance with the wiring rules for design of electrical units, and has a contact separation in all poles that allows for full disconnection under overvoltage category III conditions.

CAUTION: In order to avoid a safety hazard due to inadvertent resetting of the thermal cut-out, this unit must not be supplied through an external switching device, such as a timer, or connected to a circuit that is regularly switched on and off by the utility.

This unit is not intended for use by persons (including children) with reduced physical, sensory or mental capabilities, or lack of experience and knowledge, unless they have been given supervision or instruction concerning use of the unit by a person responsible for their safety. Children should be supervised to ensure that they do not play with the unit.

This appliance can be used by children aged from 8 years and above and persons with reduced physical, sensory or mental capabilities or lack of experience and knowledge if they have been given supervision or instruction concerning use of the appliance in a safe way and understand the hazards involved.

Cleaning and user maintenance shall not be done by children without supervision. Children shall not play with the appliance.

Ensure that the unit is switched off from the supply mains before removing the guard.

Precautions must be taken to avoid the back-flow of gases into the room from the open flue of gas or other fuel-burning appliances.

The appliance may adversely affect the safe operation of appliances burning gas or other fuels (including those in other rooms) due to back flow of combustion gases. These gases can potentially result in carbon monoxide poisoning. After installation of the unit the operation of flued gas appliances should be tested by a competent person to ensure that back flow of combustion gases does not occur.

All operations described in this manual must be performed by qualified personnel only, properly trained and qualified to install, make electrical connections and maintain ventilation units. Do not attempt to install the product, connect it to the mains, or perform maintenance yourself. This is unsafe and impossible without special knowledge.

Disconnect the power supply prior to any operations with the unit.

All user's manual requirements as well as the provisions of all the applicable local and national construction, electrical, and technical norms and standards must be observed when installing and operating the unit.

Disconnect the unit from the power supply prior to any connection, servicing, maintenance, and repair operations.

Connection of the unit to power mains is allowed by a qualified electrician with a work permit for the electric units up to 1000 V after careful reading of the present user's manual.

Check the unit for any visible damage of the impeller, the casing, and the grille before starting installation. The casing internals must be free of any foreign objects that can damage the impeller blades.

While mounting the unit, avoid compression of the casing! Deformation of the casing may result in motor jam and excessive noise.

Misuse of the unit and any unauthorised modifications are not allowed.

Transported air must not contain any dust or other solid impurities, sticky substances, or fibrous materials.

Do not use the unit in a hazardous or explosive environment containing spirits, gasoline, insecticides, etc.

Do not close or block the intake or extract vents in order to ensure the efficient air flow.

Do not sit on the unit and do not put objects on it.

The information in this user's manual was correct at the time of the document's preparation.

The Company reserves the right to modify the technical characteristics, design, or configuration of its products at any time in order to incorporate the latest technological developments.

Never touch the unit with wet or damp hands.

Never touch the unit when barefoot.

BEFORE INSTALLING ADDITIONAL EXTERNAL DEVICES, READ THE RELEVANT USER MANUALS.

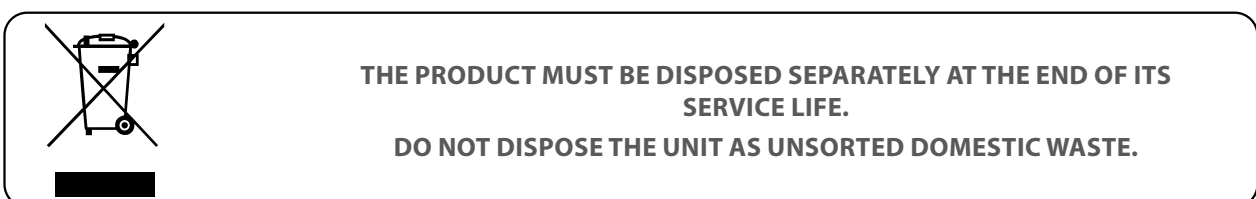

PURPOSE



THE UNIT SHOULD NOT BE OPERATED BY CHILDREN OR PERSONS WITH REDUCED PHYSICAL, MENTAL, OR SENSORY CAPACITIES, OR THOSE WITHOUT THE APPROPRIATE TRAINING.

THE UNIT MUST BE INSTALLED AND CONNECTED ONLY BY PROPERLY QUALIFIED PERSONNEL AFTER THE APPROPRIATE BRIEFING.

THE CHOICE OF UNIT INSTALLATION LOCATION MUST PREVENT UNAUTHORISED ACCESS BY UNATTENDED CHILDREN.

Electric axial fans are designed for direct extraction of indoor air outdoors and supply of fresh outdoor air into the premises.

The unit is a component part and is not designed for stand-alone operation.

The unit is rated for continuous operation.

Transported air must not contain any flammable or explosive mixtures, evaporation of chemicals, sticky substances, fibrous materials, coarse dust, soot and oil particles or environments favorable for the formation of hazardous substances (toxic substances, dust, pathogenic germs).

DELIVERY SET

OV / OVK / VKF / OV1 / OVK1 / OV1 R

NAME	NUMBER
Fan	1 piece
User's manual	1 piece
Packing	1 piece

OVP / VKOM(z) / VKOM1(z)

NAME	NUMBER
Fan	1 piece
Mounting brackets	2 pieces
User's manual	1 piece
Packing	1 piece

DESIGNATION KEY

Designation example: **OVK 4E 200**

Model	└─	└─	└─
OV: axial fans with a square plate			
OVK: axial fans with a round plate			
VKF: duct axial fan with a connection flange			
OVP: duct axial fan			
Number of poles	└─	└─	└─
Phases	└─	└─	└─
E: single-phase			
D: three-phase			
Standard size	└─	└─	└─

Designation example: **VKOMz 200**

Model	└─	└─	└─
OV1: axial fan with a square plate			
OVK1: axial fan with a round plate			
OV1 R: axial fan with a plastic grille			
VKOM: duct axial fan in a metal casing			
VKOM1: duct axial fan in a metal casing, corrugated edges			
Casing material	└─	└─	└─
_: polymer coated steel			
z: galvanized steel			
Standard size	└─	└─	└─

TECHNICAL DATA

The unit is rated as a Class I electrical appliance.

The corrosive aggressiveness of the handled medium to carbon steels of ordinary quality must be equal to that of air at temperatures ranging from -25 °C to +40/60 °C. In addition to that the handled media must be free from dust and other hard impurities as well as sticky substances and fibrous materials.



Model	Dimensions [mm]					Weight [kg]
	Ø D	Ø d	B	B1	L	
OV 2E 200	210	7	312	260	125	3.0
OV 2E 250 / OV 2D 250	260	7	370	320	135	4.0
OV 4E 250 / OV 4D 250	260	7	370	320	135	3.5
OV 2E 300 / OV 2D 300	317	9	430	380	145	6.1 / 5.4
OV 4E 300 / OV 4D 300	317	9	430	380	145	5.0 / 5.4
OV 4E 350 / OV 4D 350	374	9	485	435	165	7.8
OV 4E 400 / OV 4D 400	416	9	540	490	220	8.8
OV 4E 450 / OV 4D 450 OV 6E 450 / OV 6D 450	465	11	576	535	230	10.5
OV 4E 500 / OV 4D 500 OV 6E 500 / OV 6D 500	520	11	655	615	250	14.0
OV 4E 550 / OV 4D 550 OV 6E 550 / OV 6D 550	570	11	725	675	260	16.5
OV 4E 630 / OV 4D 630 OV 6E 630 / OV 6D 630	650	11	800	710	275	20.0
OV 6D 710 / OV 8D 710	725	13	900	810	350	33.0
OV 6D 800 / OV 8D 800	800	13	970	910	350	44.0

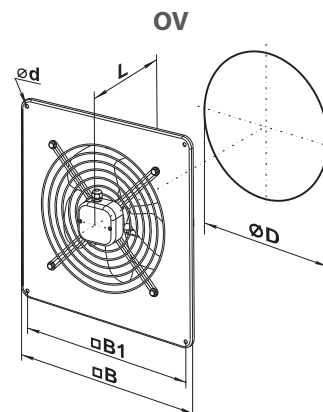

Model	Dimensions [mm]					Weight [kg]
	Ø D	Ø D1	Ø D2	Ø d	L	
OVK 2E 200	210	250	280	7	125	2.8
OVK 2E 250 / OVK 2D 250	260	318	340	7	135	3.8
OVK 4E 250 / OVK 4D 250	260	318	340	7	135	3.4
OVK 2E 300 / OVK 2D 300	317	380	397	9	145	5.9 / 5.1
OVK 4E 300 / OVK 4D 300	317	380	397	9	145	5.0 / 5.1
OVK 4E 350 / OVK 4D 350	374	442	460	9	165	7.5
OVK 4E 400 / OVK 4D 400	417	504	528	9	220	8.5
OVK 4E 450 / OVK 4D 450 OVK 6E 450 / OVK 6D 450	465	578	607	11	230	10.0
OVK 4E 500 / OVK 4D 500 OVK 6E 500 / OVK 6D 500	520	590	655	11	250	14.0
OVK 4E 550 / OVK 4D 550 OVK 6E 550 / OVK 6D 550	570	645	710	11	260	16.5
OVK 4E 630 / OVK 4D 630 OVK 6E 630 / OVK 6D 630	650	760	800	11	275	20.0
OVK 6D 710 / OVK 8D 710	725	820	890	13	350	31.0
OVK 6D 800 / OVK 8D 800	800	900	970	13	350	42.0

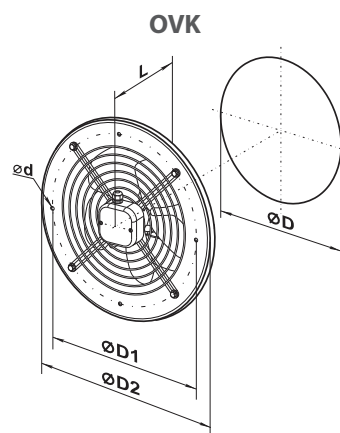

Model	Dimensions [mm]						Weight [kg]
	Ø D	Ø D1	Ø D2	Ø d	B	L	
VKF 2E 200	205	235	255	7	290	120	3.0
VKF 2E 250/VKF 2D 250	260	286	306	7	340	150	3.9
VKF 4E 250/VKF 4D 250	260	286	306	7	340	150	4.0
VKF 2E 300/VKF 2D 300	310	356	382	7	410	160	6.2 / 5.7
VKF 4E 300/VKF 4D 300	310	356	382	7	410	160	6.2
VKF 4E 350/VKF 4D 350	362	395	421	9.5	450	160	7.7
VKF 4E 400/VKF 4D 400	412	438	465	9.5	500	170	8.1
VKF 4E 450/VKF 4D 450 VKF 6E 450/VKF 6D 450	462	487	515	9.5	550	200	9.1
VKF 4E 500/VKF 4D 500 VKF 6E 500/VKF 6D 500	515	541	570	9.5	600	220	11.0
VKF 4E 550/VKF 4D 550 VKF 6E 550/VKF 6D 550	565	605	636	11.5	660	230	13.9
VKF 4E 630/VKF 4D 630 VKF 6E 630/VKF 6D 630	645	674	715	11.5	740	250	16.4
VKF 6D 710/VKF 8D 710	725	767	805	11.5	835	250	30.0
VKF 6D 800/VKF 8D 800	800	845	880	11.5	910	280	40.0

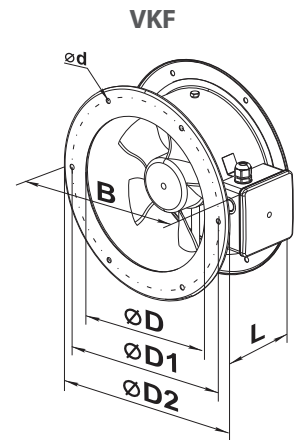

Model	Dimensions [mm]					Weight [kg]
	Ø D	Ø D1	Ø D2	Ø d	L	
OVK1 150	162	190	220	7	120	2.5
OVK1 200	208	270	300	7	120	2.5
OVK1 250	262	330	360	7	140	3.0
OVK1 315	312	390	420	9	170	5.1

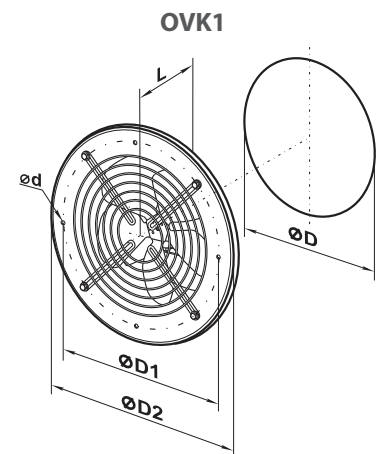

Model	Dimensions [mm]					Weight [kg]
	Ø D	Ø d	B	B1	L	
OV1 150	162	7	250	210	120	2.5
OV1 200	208	7	312	260	120	3.0
OV1 250	262	7	370	320	140	3.5
OV1 315	312	9	430	380	170	6.1

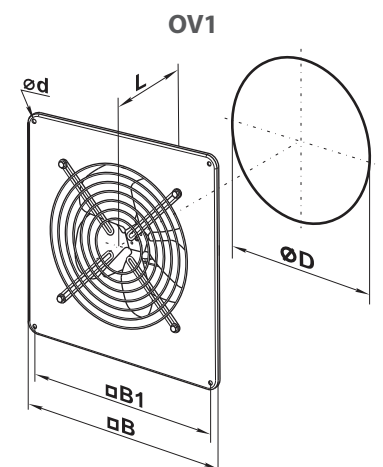

Model	Dimensions [mm]					Weight [kg]
	Ø D	B	L	H	L1	
OVP 2E 200	199	227	220	300	30	3.5
OVP 2E 250	249	282	250	320	30	4.5
OVP 4E 250	249	282	250	320	30	4.5
OVP 2E 300	299	326	250	390	40	6.3
OVP 4E 300	299	326	250	390	40	6.3
OVP 4E 350	349	378	300	410	40	8.4

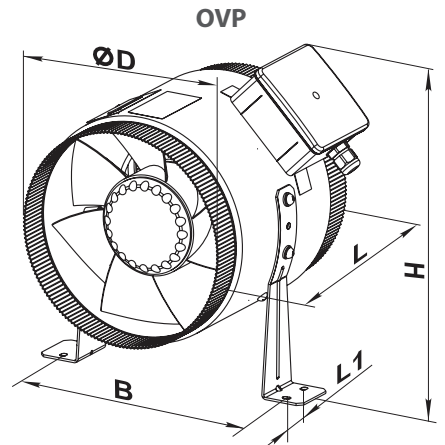

Model	Dimensions [mm]					Weight [kg]
	Ø D	B	L	L1	L3	
VKOM1(z) 150	149	183	220	35	30	1.8
VKOM1(z) 200	299	228	220	35	30	2.4
VKOM1(z) 250	249	283	270	35	30	3.7

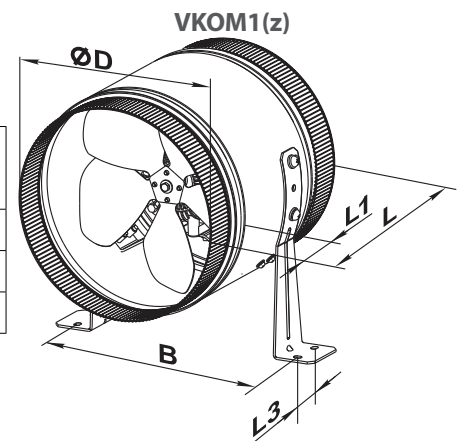

Model	Dimensions [mm]					Weight [kg]
	Ø D	B	L	L1	L3	
VKOM(z) 150	162	183	220	40	30	1.8
VKOM(z) 200	208	228	220	40	30	2.4
VKOM(z) 250	262	283	270	55	30	3.7
VKOM(z) 315	315	337	278	55	40	4.9

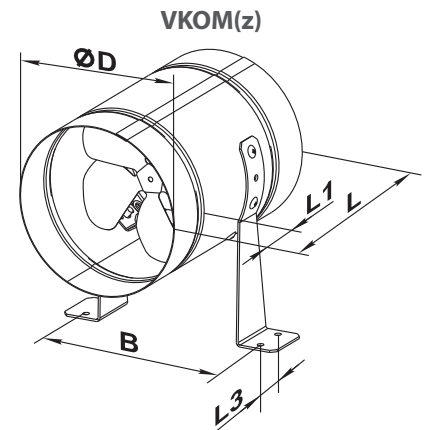

The **VKOM(z)** fans are equipped with **RM(z)** (polymer-coated steel, galvanised steel) reducers for connection to 150 mm, 200 mm and 250 mm air ducts.
The reducers are not included in the delivery set and must be ordered separately.

Model	Dimensions [mm]				Weight [kg]
	Ø D	Ø D1	H	H1	
RM(z) 148/158	148	158	140	55	0.3
RM(z) 198/204	198	204	140	55	0.4
RM(z) 248/258	248	258	150	65	0.42

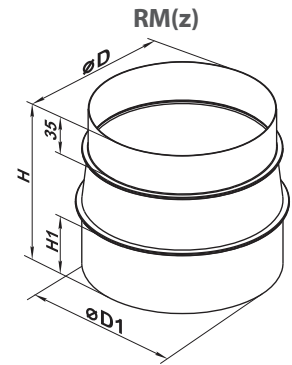

Model	Dimensions [mm]					Weight [kg]
	Ø D	Ø d	B	B1	L	
OV1 150 R	162	7	325	275	127	2.5
OV1 200 R	208	7	325	275	127	3.0
OV1 250 R	262	7	325	275	152	3.5

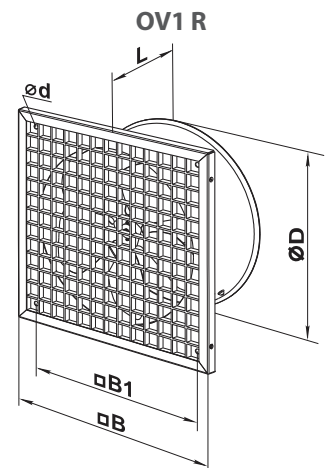

UNIT DESIGN AND OPERATING PRINCIPLE

The **OV** and **OVK** fans consist of a casing 1 with a square or a round flange with a grille fixed with bolts 4 and complete with an electric motor and impeller 5. The impeller rotation direction depends on the type of electric motor and external rotor used. The bolts attaching the impeller to the grille also serve as attachment bolts for the terminal box 3. Some models may be equipped with a cable with a terminal box for remote connection. The casing has an M4 threaded hole and yellow-green cables for connection to the protective ground circuit.

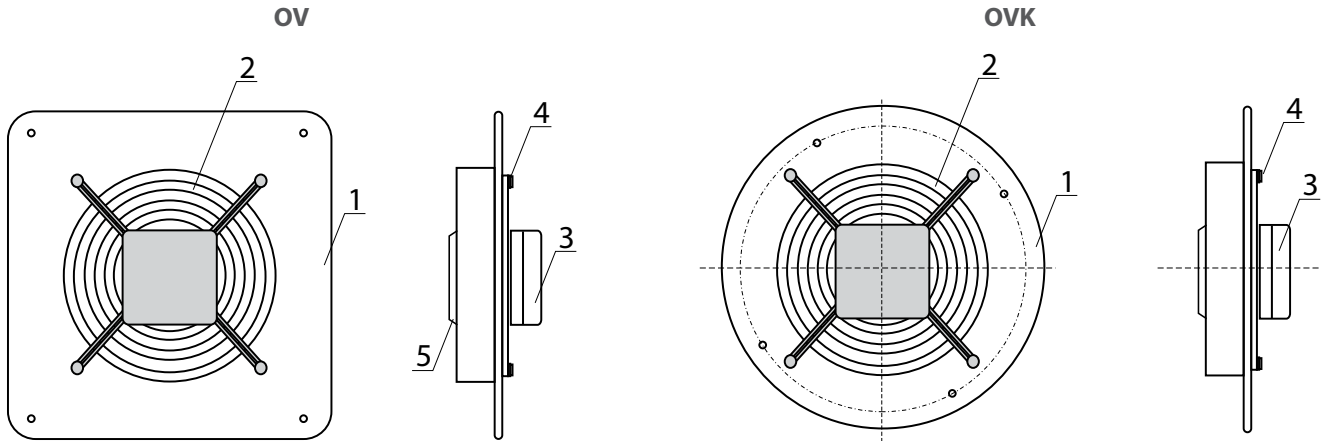

The **OV1** and **OVK1** fans consist of a casing 1 made of polymer-coated stainless steel with a square (**OV1**) or round (**OVK1**) flange, to which the grille 2 is fastened with bolts 4. The motor and impeller 5 are mounted on a bracket inside the casing. The fans are equipped with a terminal box with a cable for remote connection.

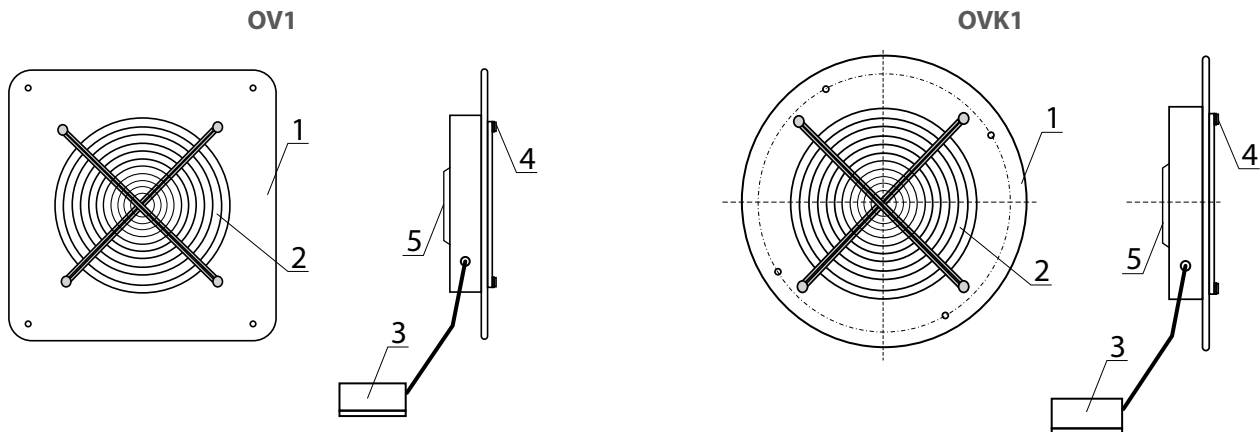

The **VKF** fan consists of a casing 1 with round flanges on both sides providing connection for a cross piece complete with an electric motor and impeller 4 fixed with bolts 3. The impeller rotation direction depends on the type of electric motor used. The electric motor casing has an M4 threaded hole and yellow-green cables for connection to the protective ground circuit.

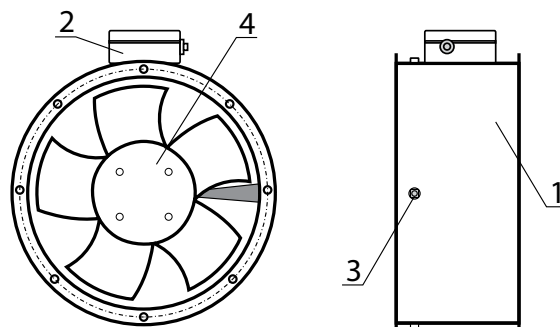

OVP, VKOM(z), VKOM1(z) fans

The brackets 2 are attached to the casing with bolts 1. The electric motor with the impeller 4 is mounted on the bracket 3 inside the casing. The terminal box 5 mounted onto the **OVP** fan casing provides connection to power mains.

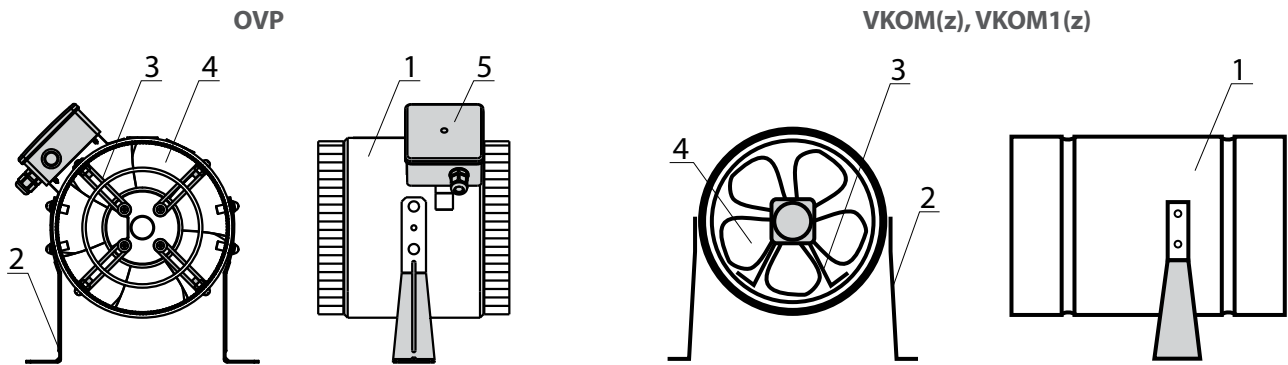

The **OV1 R** fan consists of a steel casing 1 with a square flange. The casing has a polymer coating. The motor and impeller 5 are mounted on a bracket inside the casing. The plastic grille 2 is mounted inside the casing 1 and secured with a frame 3. The fans are equipped with a terminal box 4 on a cable for electrical connection.

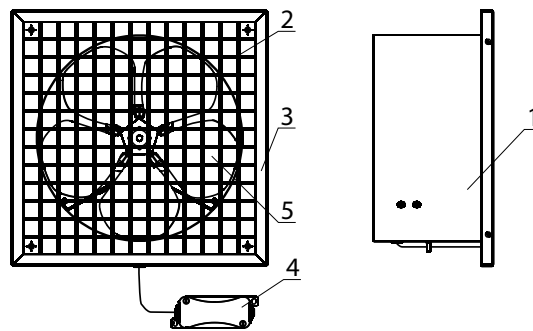

MOUNTING AND SET-UP



BEFORE MOUNTING MAKE SURE THE CASING DOES NOT CONTAIN ANY FOREIGN OBJECTS (E.G. FOIL, PAPER).



WHILE INSTALLING THE UNIT ENSURE CONVENIENT ACCESS FOR SUBSEQUENT MAINTENANCE AND REPAIR.

- Unpack the fan and check for any cuts in the electric wires and cracks in the insulation. Inspect the fan casing to make sure it is free from any cracks and deformations. Set the impeller in motion and check that it rotates freely without catching against the inlet flange and the casing.
- Prior to powering up the fan make sure that the mains parameters comply with the technical specifications on the fan label attached to the protective casing.
- The fan mounting locations must enable adequate access for maintenance, technical service and replacement operations.
- When the service conditions may lead to water ingress, the fans must be equipped with adequate protection. For example, the fans may be installed under a canopy or a roof.
- Since the fan belongs to Class 1 in terms of electrical hazard protection proper grounding is a must: to ground the equipment, connect the \ominus terminal to the protective ground circuit.

The fans are installed on wall surfaces by means of a mounting casing with attachment holes:

- **OV, OV1**, series with a square casing — 4 holes.
- **OVK, OVK1** series with a round casing — 6 holes.

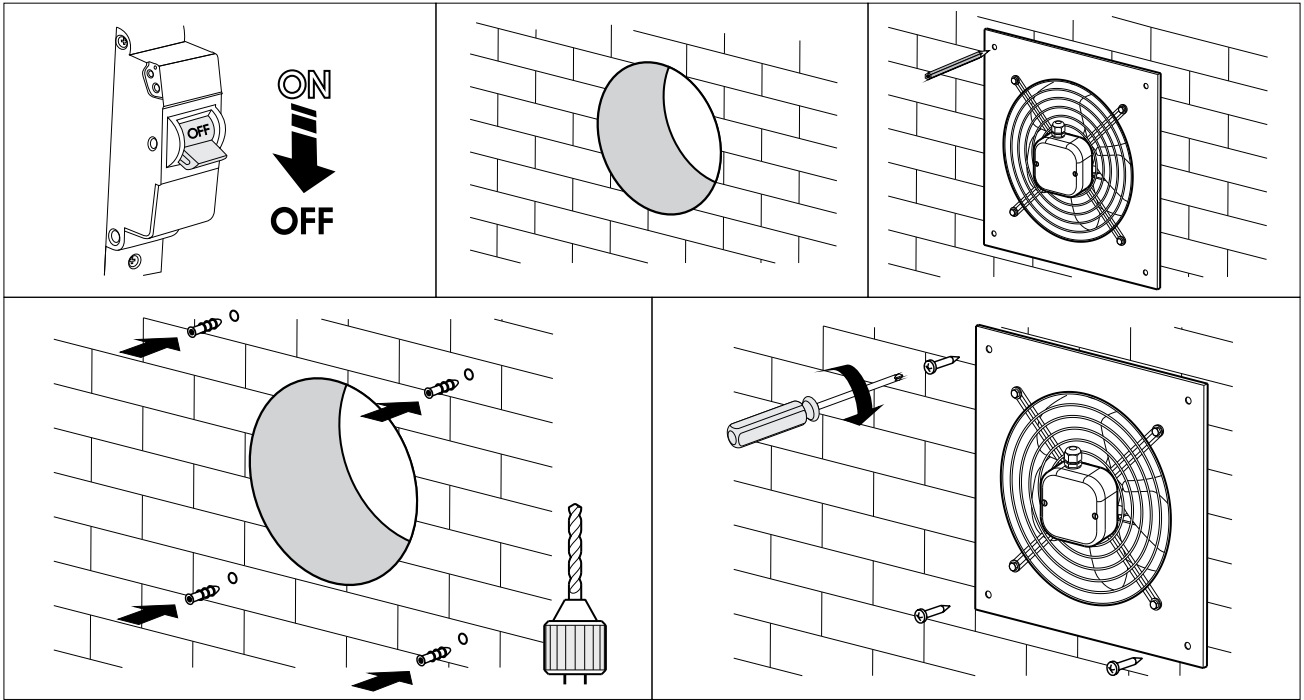
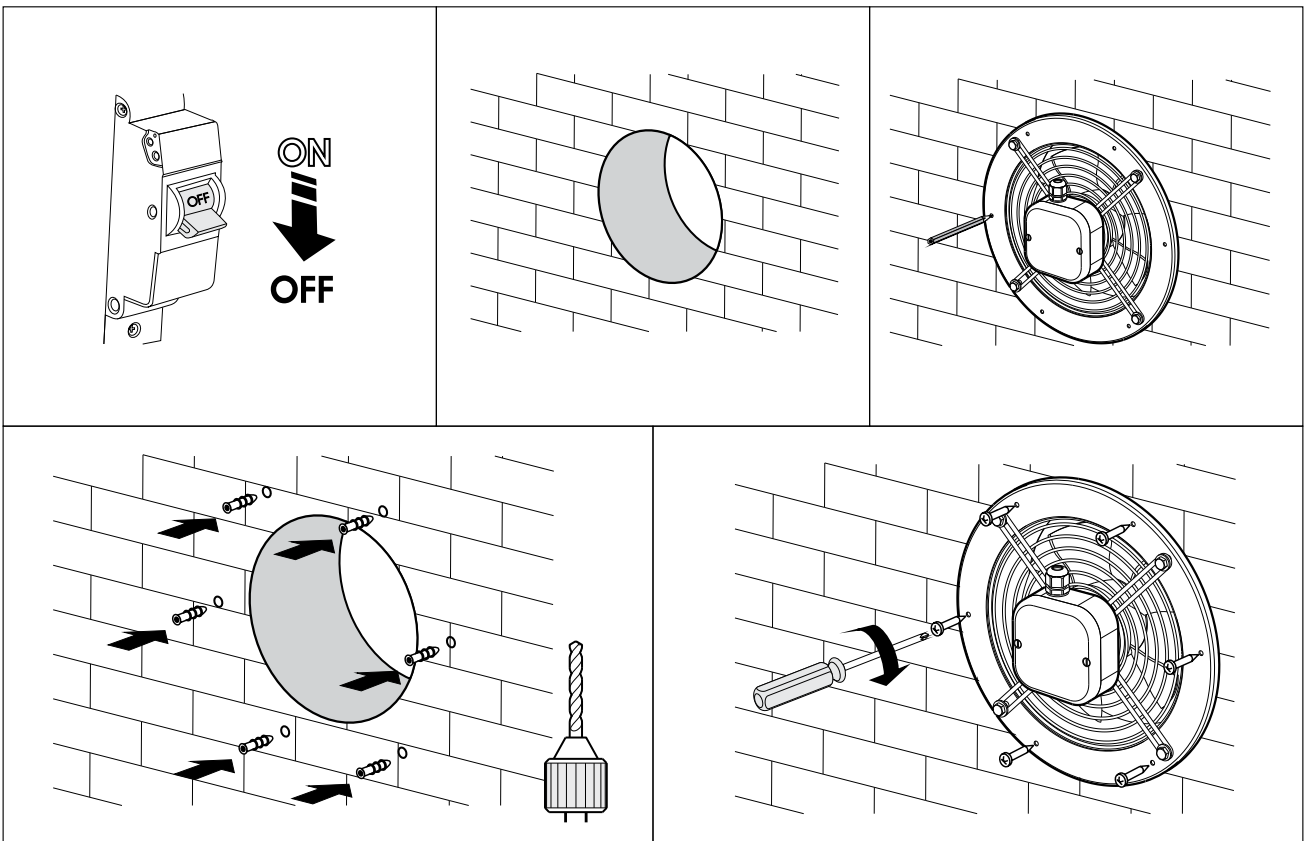
OV fan installation**OVK fan installation**

OV1 and OVK1 fan installation

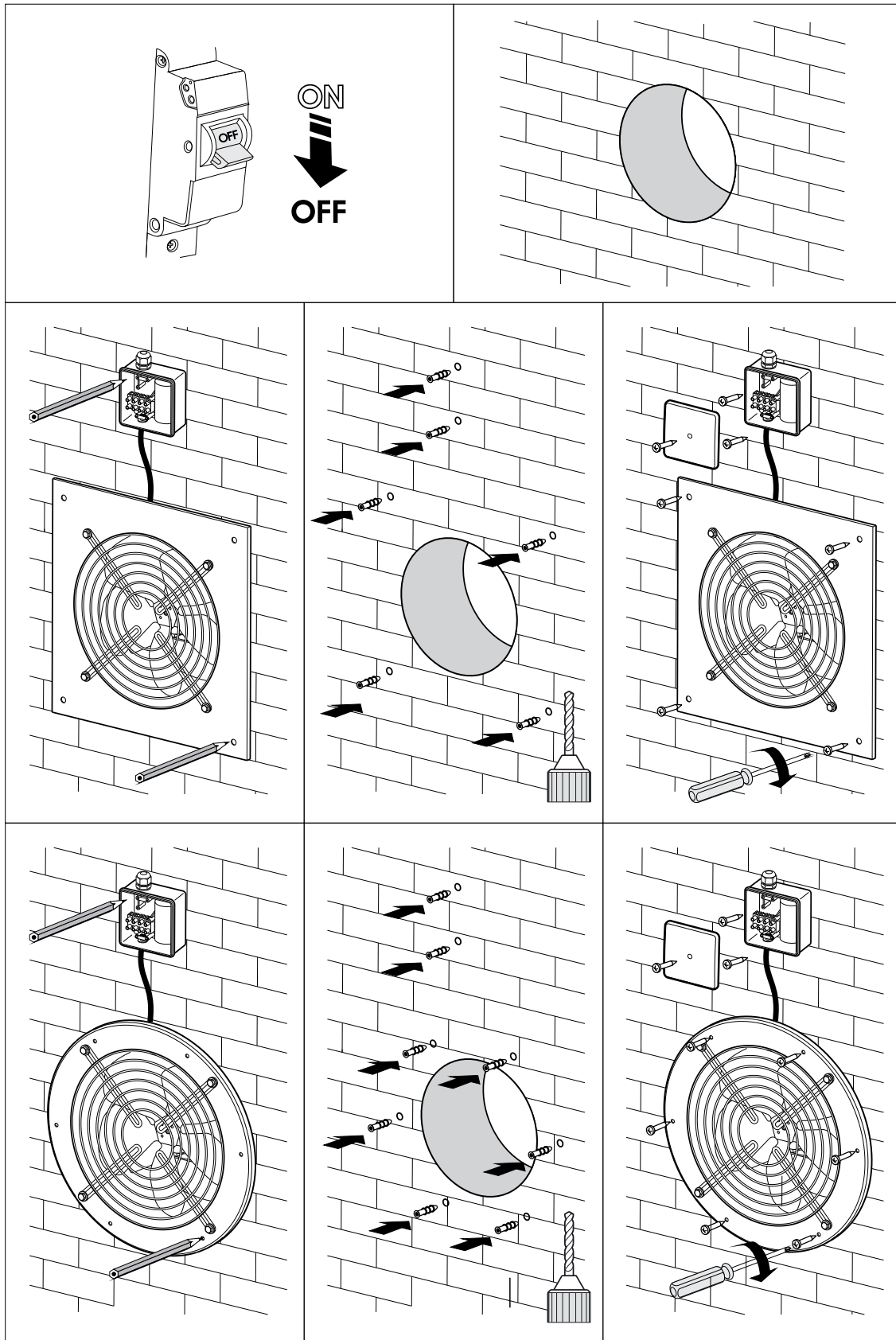

VKF fan installation

The fans are installed into air ducts by means of connection flanges. The fan must be installed in such a way so that the direction of the arrow shown on the casing matches the direction of air flow in the system. The power is supplied via the remote-position terminal box.

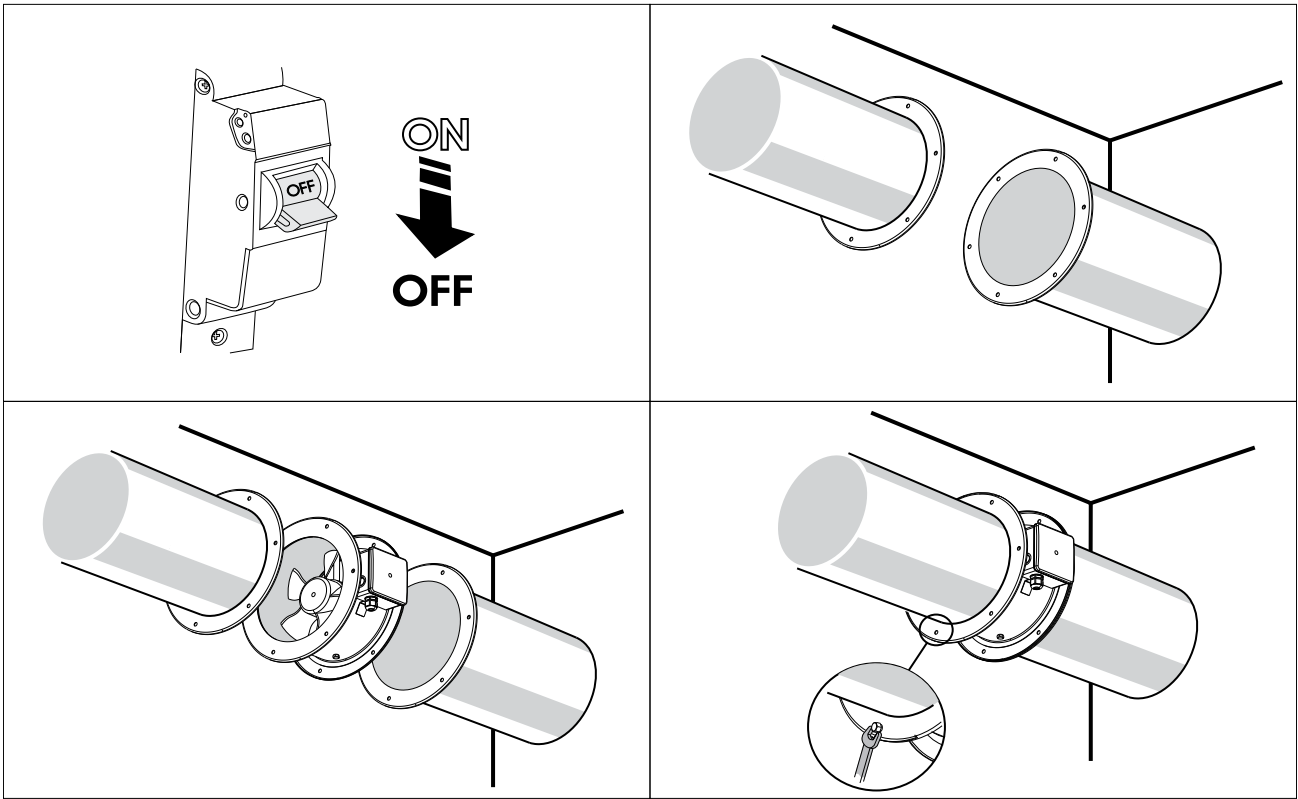

OVP and VKOM1(z) fan installation

The fans are installed into air ducts by means of clamps. The delivery set includes mounting brackets for attaching the units to the ceiling or a wall. The power is supplied via an external terminal box mounted to the fan casing.

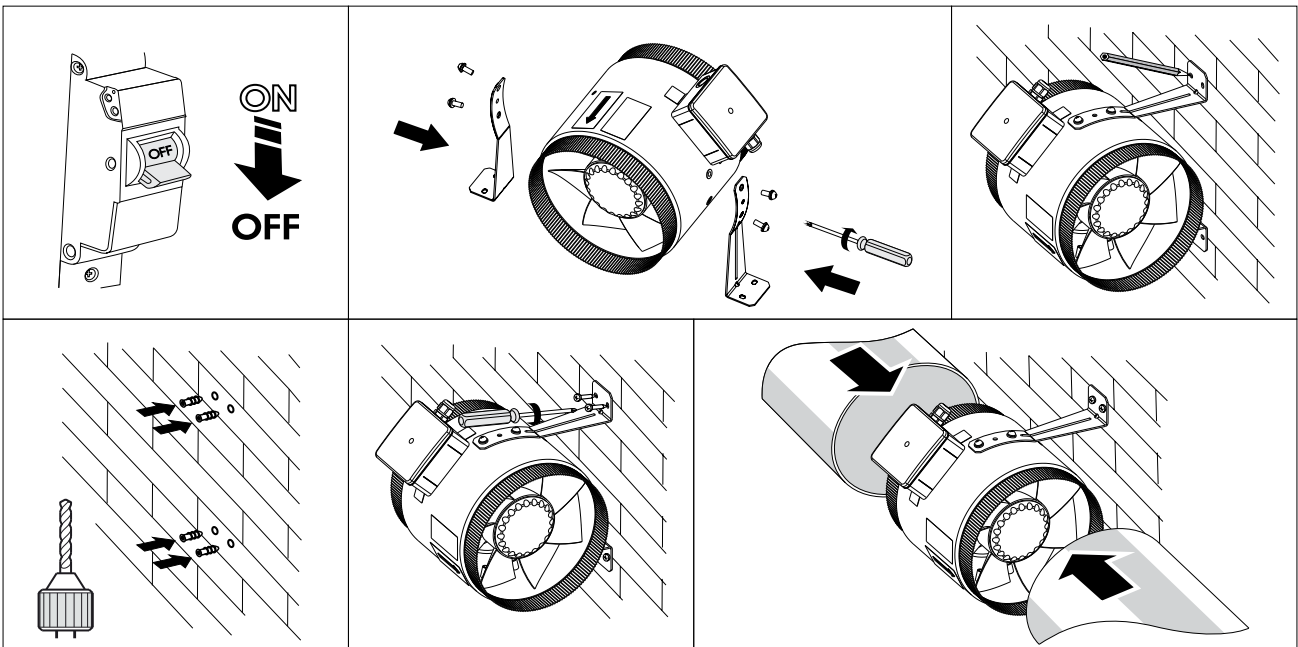

VKOM(z) fan installation

The fans are installed into air duct by means of an **RM(z)** reducer which enables joining different diameter ducts. Once done, the assembly is secured with clamps. The power is supplied via terminal box on the fan casing. The **VKOM(z)** delivery set includes mounting brackets for attaching the unit to the mounting surface. Depending on a delivery set, two mounting options are possible:

1.

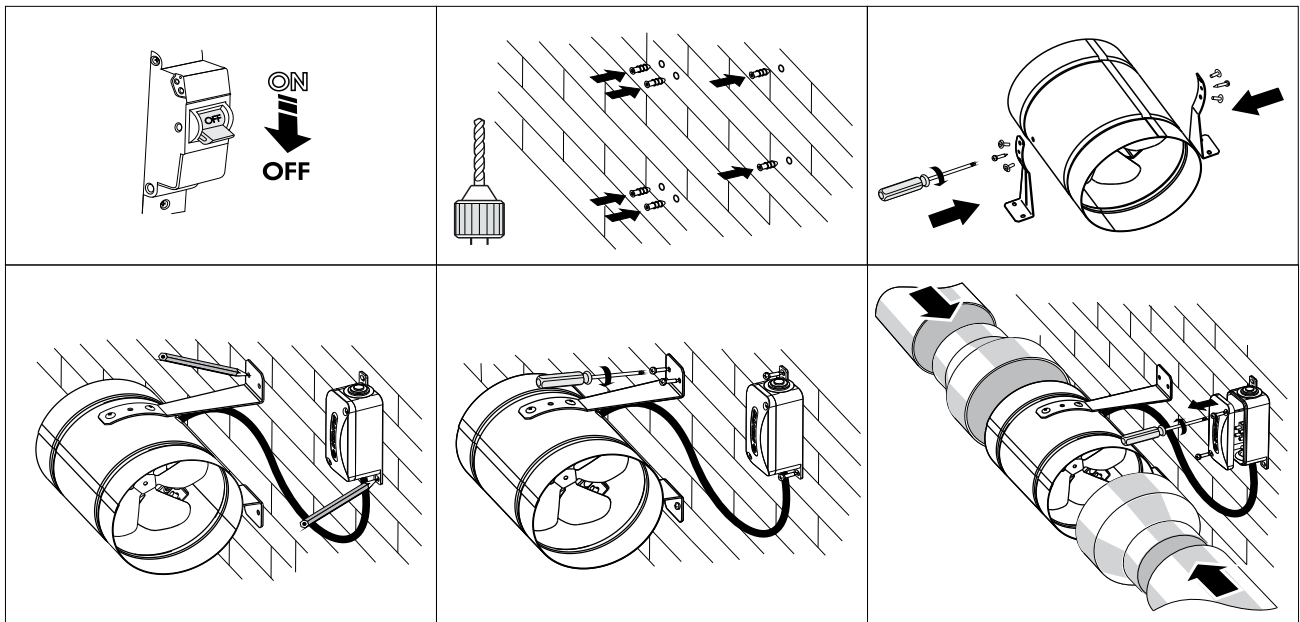

2. Note: the mounting bracket fixing point on the fan casing must be selected so that the screws do not interfere with the free rotation of the impeller.

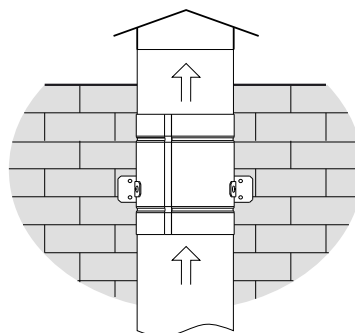
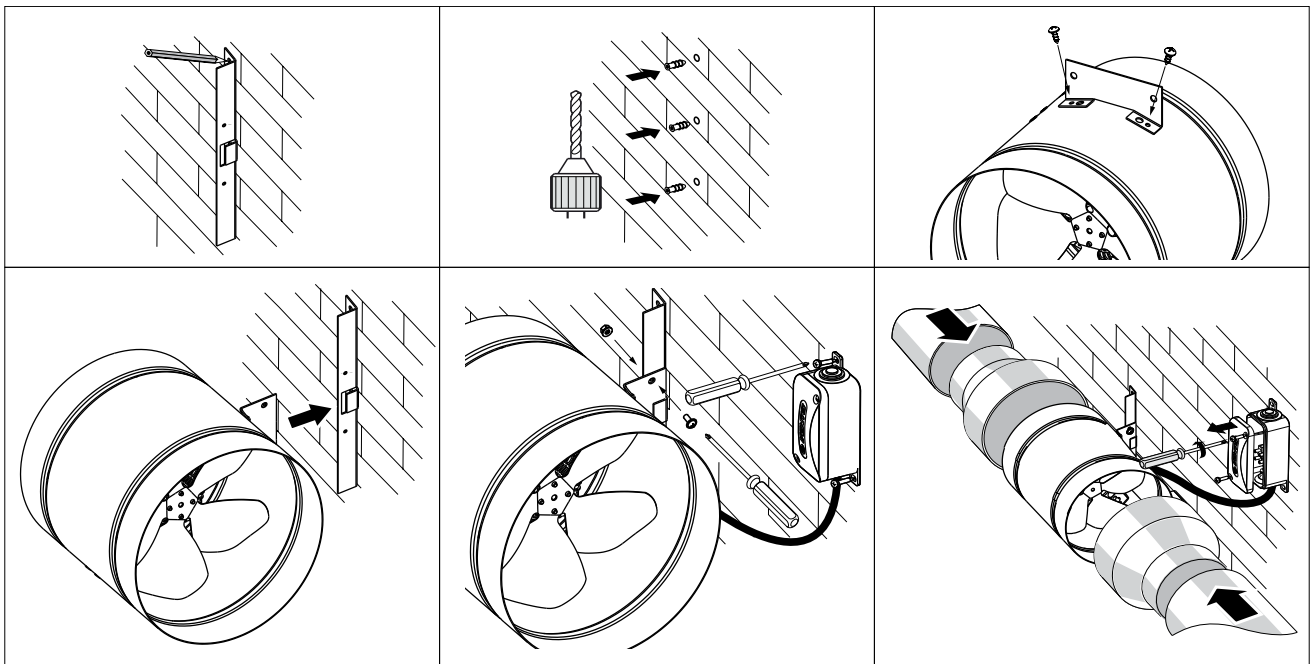

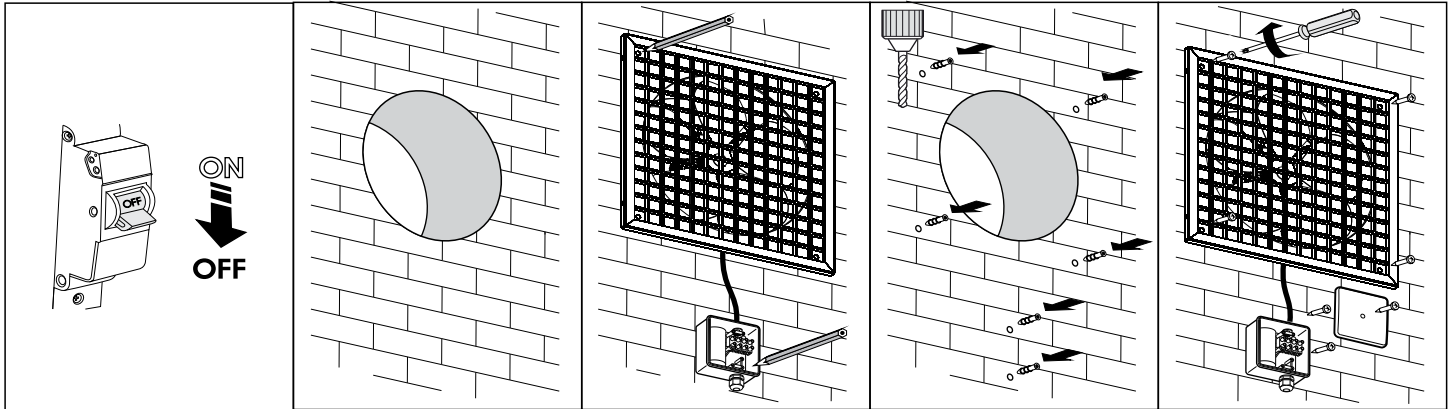
OV1 R fan installation

CONNECTION TO POWER MAINS

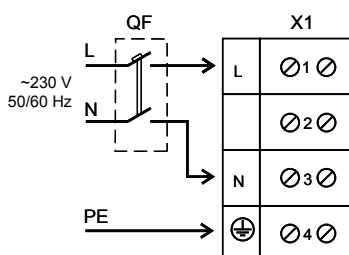

**POWER OFF THE POWER SUPPLY PRIOR TO ANY OPERATIONS WITH THE UNIT.
THE UNIT MUST BE CONNECTED TO POWER SUPPLY BY A QUALIFIED ELECTRICIAN.
THE RATED ELECTRICAL PARAMETERS OF THE UNIT ARE GIVEN ON THE
MANUFACTURER'S LABEL.**

- The unit is rated for connection to power mains with the parameters specified in the «Technical data» section, according to the wiring diagram.
- The connection must be made using durable, insulated and heat-resistant conductors (cables, wires). The actual wire cross section selection must be based on the maximum load current, maximum conductor temperature depending on the wire type, insulation, length and installation method.
- Connect the unit to power mains in accordance with the wiring diagram and terminal designations.
- The external power input must be equipped with an automatic circuit breaker (QF) built into the stationary wiring to open the circuit in the event of overload or short-circuit. The position of the external automatic circuit breaker must ensure free access for quick power-off of the unit. The trip current of the automatic circuit breaker must exceed the maximum current consumption of the unit (refer to the «Technical data» section or to the unit label). The recommended trip current of the circuit breaker is the next current in the standard trip current row following the maximum current of the connected unit. The circuit breaker is not included in the delivery set and can be ordered separately.

**Connection of
OV, OVK, VKF, OVP
fans with single-phase motor**

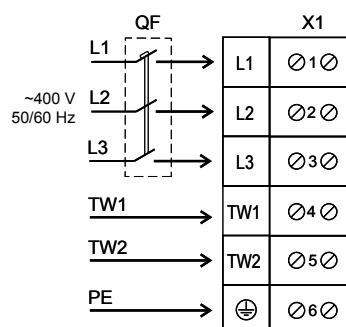

**Connection of
OV, OVK, VKF
fans with three-phase motor**



**Connection of
OV1, OVK1, VKOM(z), VKOM1(z)
fans with single-phase motor**

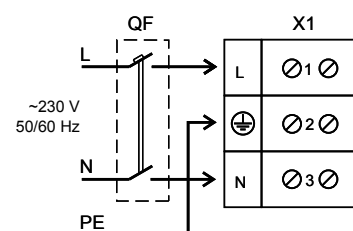

OV and OVK fan connection

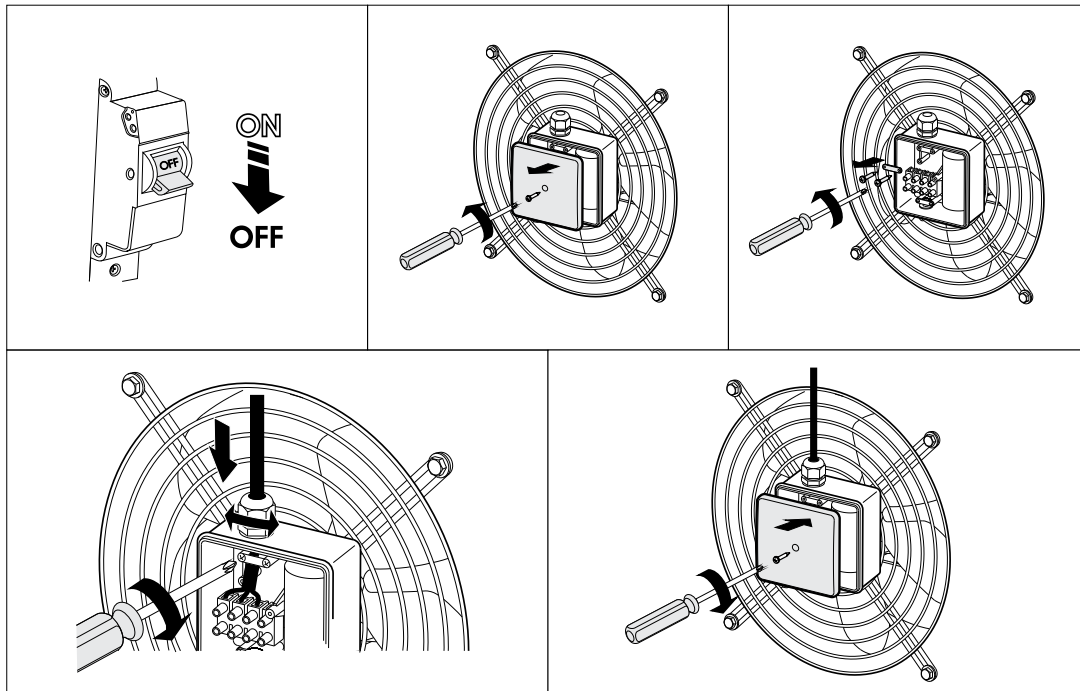

OV1 fan connection

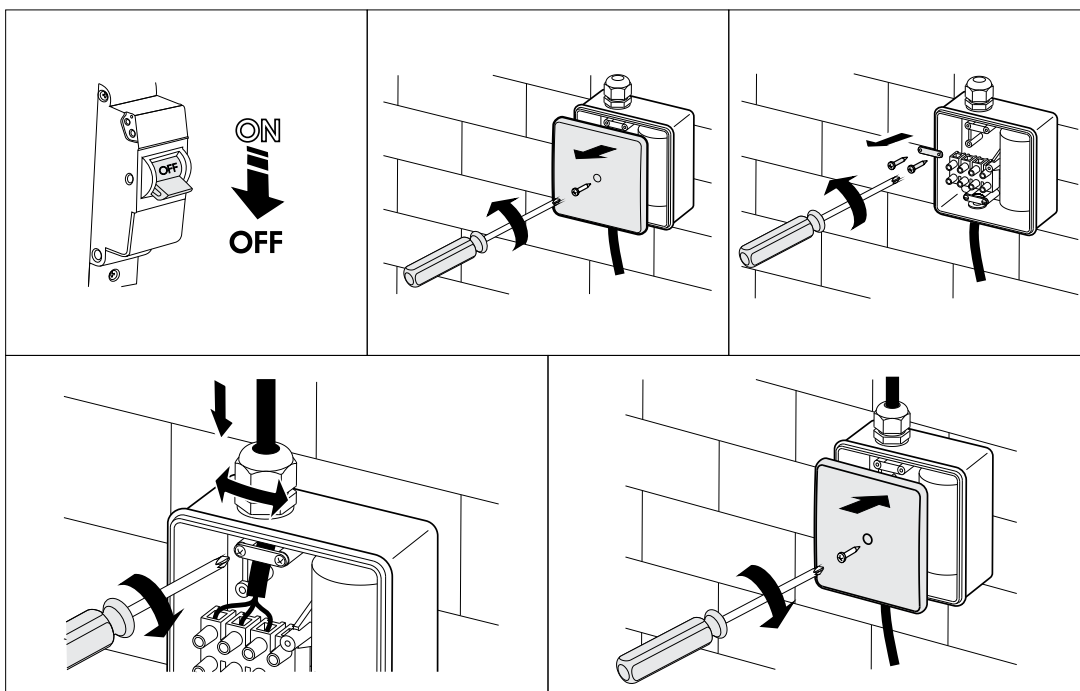

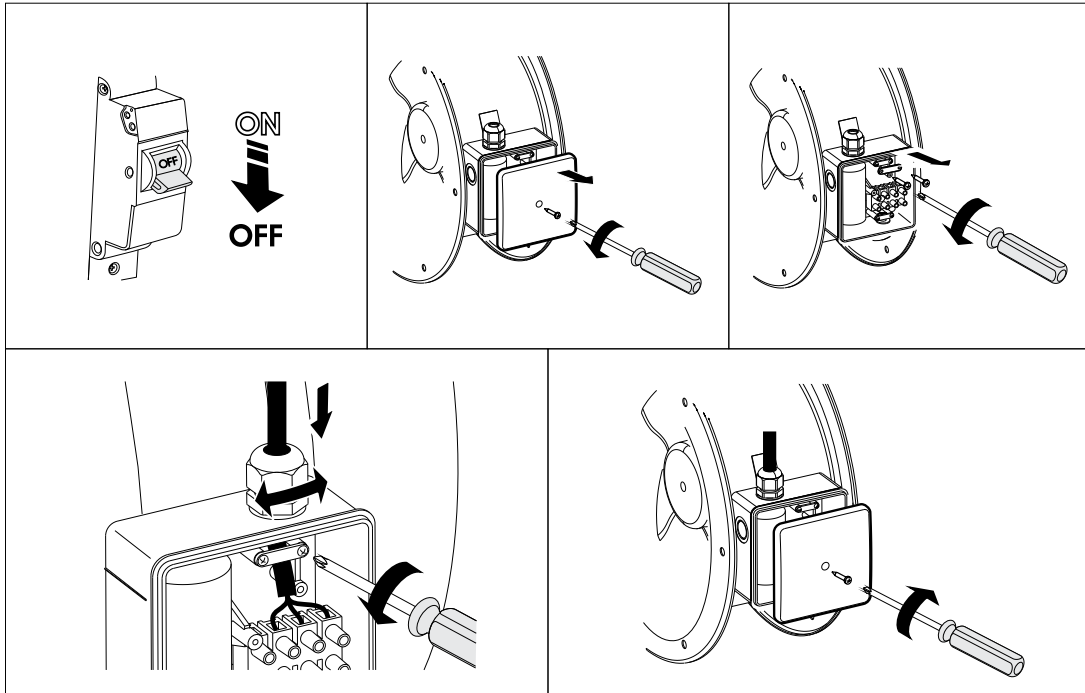
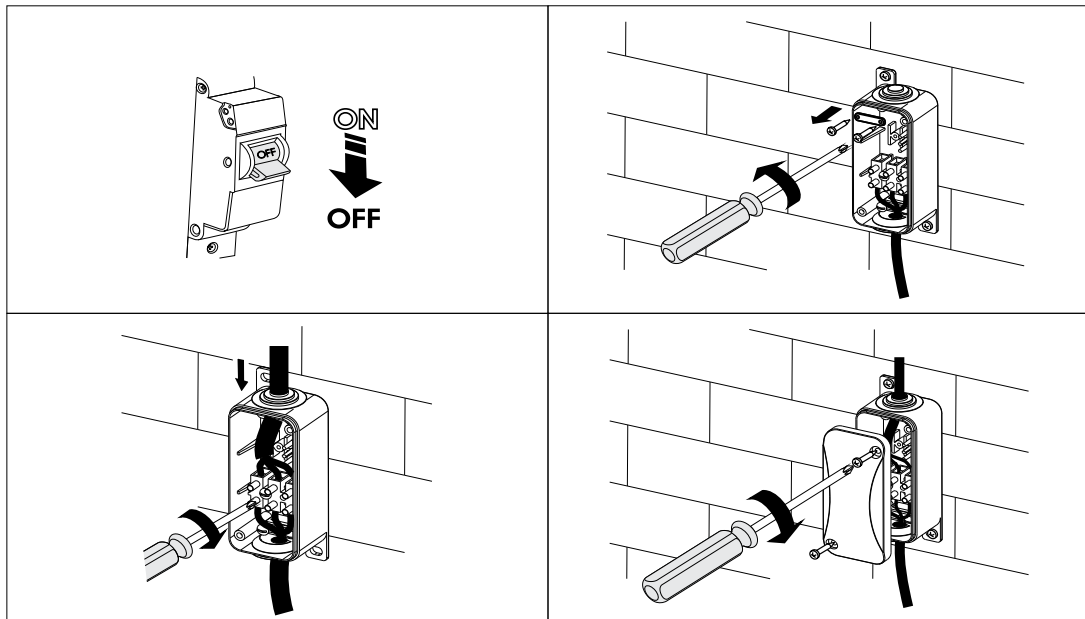
VKF, VKOM(z), VKOM1(z) fan connection

OVP fan connection

TECHNICAL MAINTENANCE



DISCONNECT THE UNIT FROM POWER SUPPLY BEFORE ANY MAINTENANCE OPERATIONS!

MAKE SURE THE UNIT IS DISCONNECTED FROM POWER MAINS BEFORE REMOVING THE PROTECTION.

All the operations specific to the technical maintenance must be performed upon disconnecting the fan from power mains. The technical maintenance includes periodic cleaning of the fan surfaces from dust and dirt. To dust off the metal parts of the fan, use a dry soft brush or a stream of compressed air. Every 6 months clean the impeller with a warm detergent solution while avoiding water penetration onto the electric motor. Wipe the cleaned surfaces dry.

To carry out technical maintenance of the **VKF, VKOM(z), VKOM1(z), OVP** fans, remove the fans from the duct by undoing the retaining bolts on the **VKF** units or disconnecting the mounting clamps on the **VKOM(z), VKOM1(z)** and **OVP** units. To carry out work on the **OV, OVK, OV1, OVK1** units, undo the bolt 4 and disconnect the grille and electric motor assembly from the casing.

OV and OVK technical maintenance

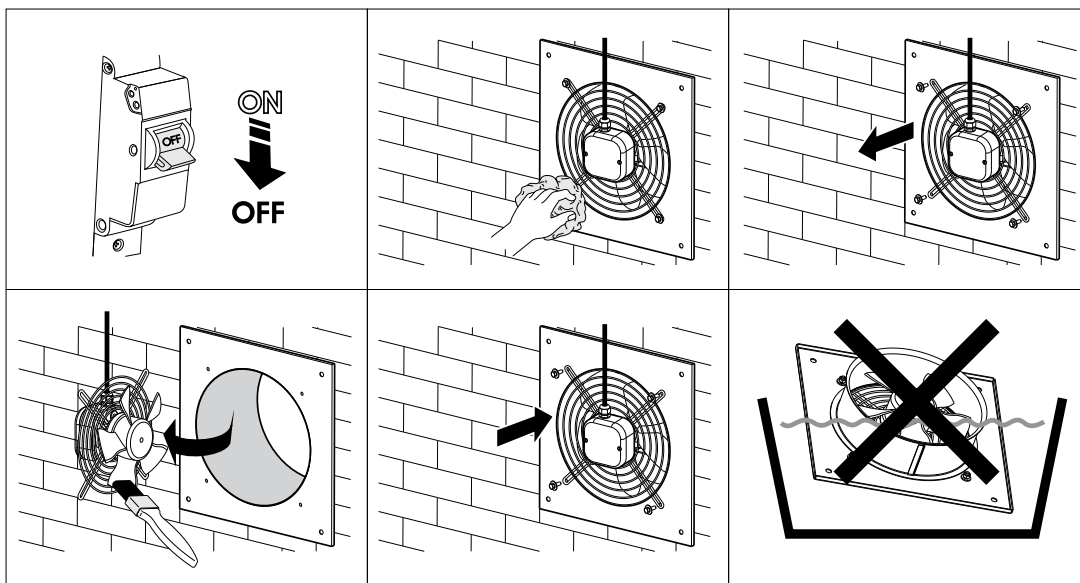

VKF technical maintenance

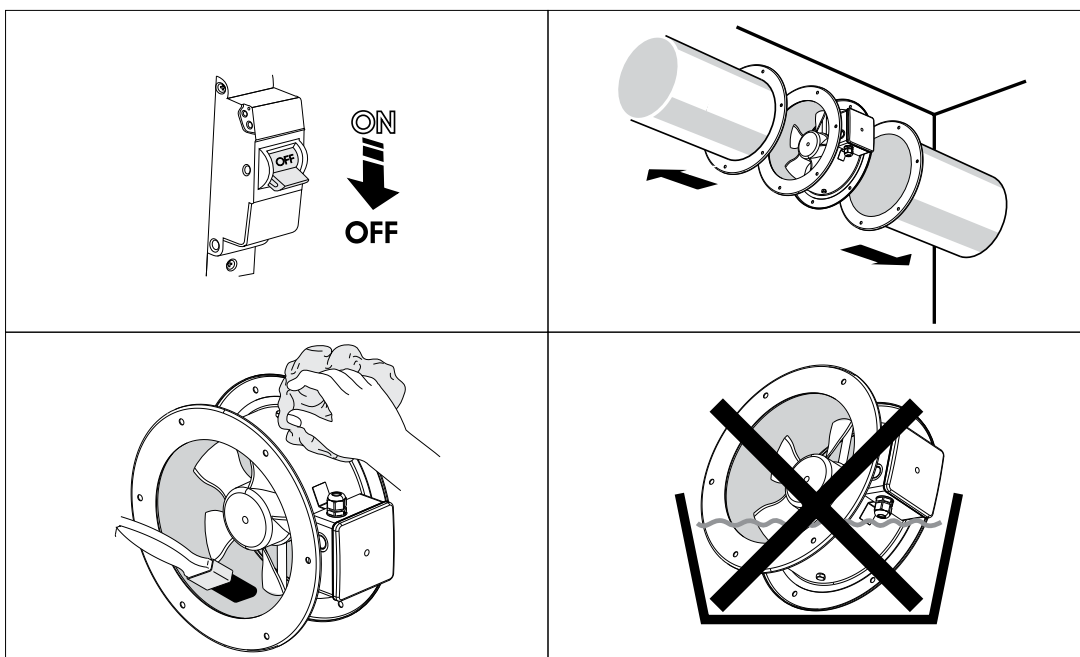

OV1 and OVK1 technical maintenance

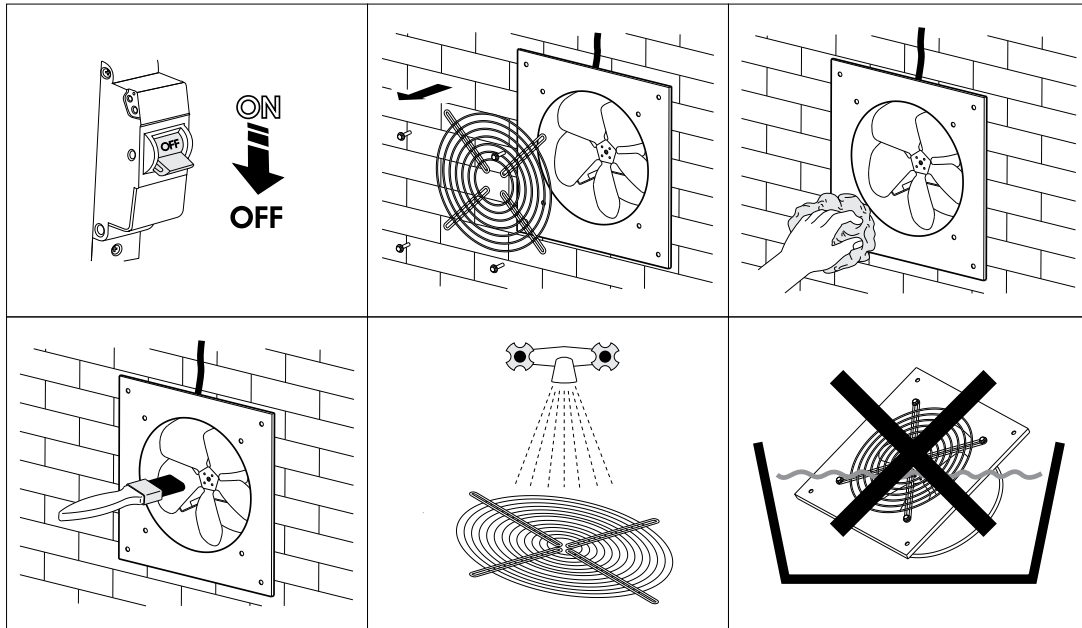

OVP, VKOM(z), VKOM1(z) technical maintenance

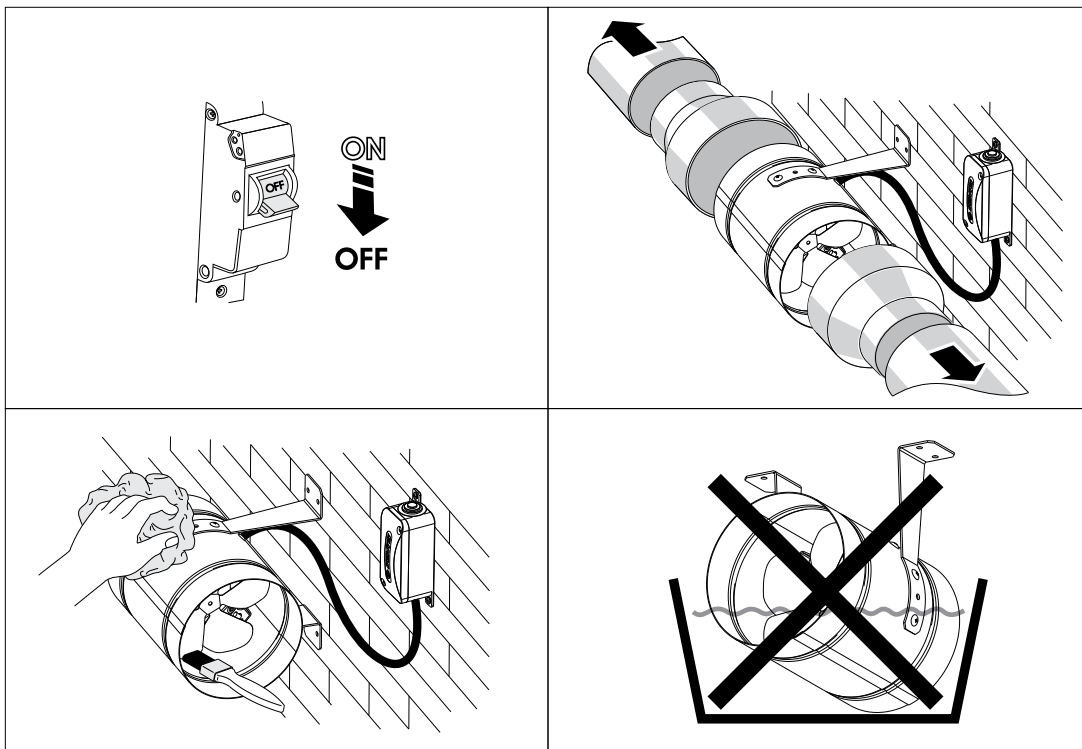

OV1 R technical maintenance

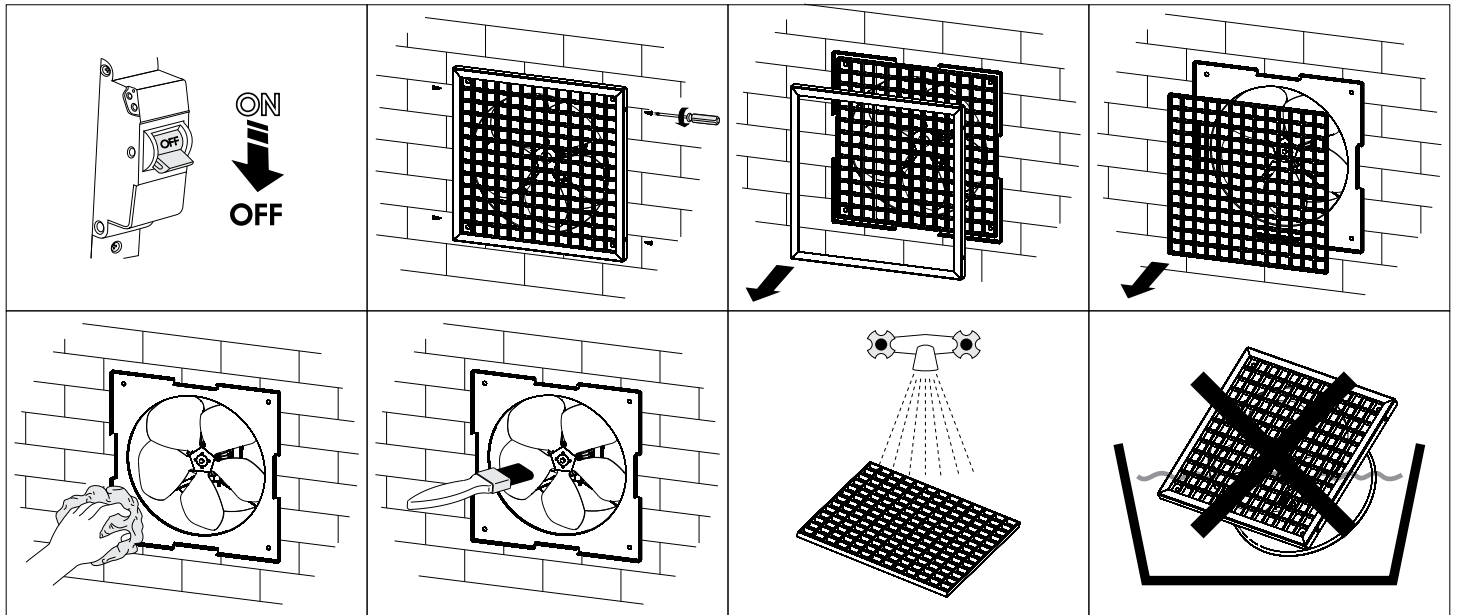

TROUBLESHOOTING

PROBLEM	POSSIBLE REASONS	TROUBLESHOOTING
The fan will not start on power-up.	No electric power.	Check the electrical connections and the power switch status.
	Motor jamming.	Switch off the fan. Eliminate the cause for the impeller clogging. Switch the fan back on.
The automatic breaker activates upon the unit power-up.	The automatic circuit breaker is triggered by abnormally high current consumption due to a short circuit.	Disconnect the fan from the power mains and contact the Seller. Do not switch on the fan again!
Low air flow.	Clogging of air ducts or other ventilation system elements due to contamination. Impeller contamination. Damaged air ducts. Closed air dampers.	Clean the air ducts and other ventilation system elements as well as the impeller. Check the air ducts for damage. Make sure that the air dampers and louvers are open.

If the malfunction is too complex to be eliminated on the spot, contact the fan Seller.

STORAGE AND TRANSPORTATION REGULATIONS

- Store the unit in the manufacturer's original packaging box in a dry closed ventilated premise with temperature range from +5 °C to +40 °C and relative humidity up to 70 %.
- Storage environment must not contain aggressive vapors and chemical mixtures provoking corrosion, insulation, and sealing deformation.
- Use suitable hoist machinery for handling and storage operations to prevent possible damage to the unit.
- Follow the handling requirements applicable for the particular type of cargo.
- The unit can be carried in the original packaging by any mode of transport provided proper protection against precipitation and mechanical damage. The unit must be transported only in the working position.
- Avoid sharp blows, scratches, or rough handling during loading and unloading.
- Prior to the initial power-up after transportation at low temperatures, allow the unit to warm up at operating temperature for at least 3-4 hours.

MANUFACTURER'S WARRANTY

The product is in compliance with EU norms and standards on low voltage guidelines and electromagnetic compatibility. We hereby declare that the product complies with the provisions of Electromagnetic Compatibility (EMC) Directive 2014/30/EU of the European Parliament and of the Council, Low Voltage Directive (LVD) 2014/35/EU of the European Parliament and of the Council and CE-marking Council Directive 93/68/EEC. This certificate is issued following test carried out on samples of the product referred to above.

The manufacturer hereby warrants normal operation of the unit for 24 months after the retail sale date provided the user's observance of the transportation, storage, installation, and operation regulations. Should any malfunctions occur in the course of the unit operation through the Manufacturer's fault during the guaranteed period of operation, the user is entitled to get all the faults eliminated by the manufacturer by means of warranty repair at the factory free of charge. The warranty repair includes work specific to elimination of faults in the unit operation to ensure its intended use by the user within the guaranteed period of operation. The faults are eliminated by means of replacement or repair of the unit components or a specific part of such unit component.

The warranty repair does not include:

- routine technical maintenance
- unit installation/dismantling
- unit setup

To benefit from warranty repair, the user must provide the unit, the user's manual with the purchase date stamp, and the payment paperwork certifying the purchase. The unit model must comply with the one stated in the user's manual. Contact the Seller for warranty service.

The manufacturer's warranty does not apply to the following cases:

- User's failure to submit the unit with the entire delivery package as stated in the user's manual including submission with missing component parts previously dismantled by the user.
- Mismatch of the unit model and the brand name with the information stated on the unit packaging and in the user's manual.
- User's failure to ensure timely technical maintenance of the unit.
- Damage to the unit casing and internal components caused by the user.
- Redesign or engineering changes to the unit.
- Replacement and use of any assemblies, parts and components not approved by the manufacturer.
- Unit misuse.
- Violation of the unit installation regulations by the user.
- Violation of the unit control regulations by the user.
- Unit connection to power mains with a voltage different from the one stated in the user's manual.
- Unit breakdown due to voltage surges in power mains.
- Discretionary repair of the unit by the user.
- Unit repair by any persons without the manufacturer's authorization.
- Expiration of the unit warranty period.
- Violation of the unit transportation regulations by the user.
- Violation of the unit storage regulations by the user.
- Wrongful actions against the unit committed by third parties.
- Unit breakdown due to circumstances of insuperable force (fire, flood, earthquake, war, hostilities of any kind, blockades).
- Missing seals if provided by the user's manual.
- Failure to submit the user's manual with the unit purchase date stamp.
- Missing payment paperwork certifying the unit purchase.



FOLLOWING THE REGULATIONS STIPULATED HEREIN WILL ENSURE A LONG AND TROUBLE-FREE OPERATION OF THE UNIT



USER'S WARRANTY CLAIMS SHALL BE SUBJECT TO REVIEW ONLY UPON PRESENTATION OF THE UNIT, THE PAYMENT DOCUMENT AND THE USER'S MANUAL WITH THE PURCHASE DATE STAMP

CERTIFICATE OF ACCEPTANCE

Unit Type	Electric axial fans
Model	
Serial Number	
Manufacture Date	
Quality Inspector's Stamp	

SELLER INFORMATION

Seller	
Address	
Phone Number	
E-mail	
Purchase Date	
This is to certify acceptance of the complete unit delivery with the user's manual. The warranty terms are acknowledged and accepted.	
Customer's Signature	

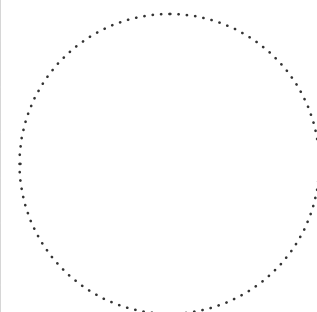

Seller's Stamp

INSTALLATION CERTIFICATE

The _____ unit is installed pursuant to the requirements stated in the present user's manual.	
Company name	
Address	
Phone Number	
Installation Technician's Full Name	
Installation Date:	Signature:
The unit has been installed in accordance with the provisions of all the applicable local and national construction, electrical and technical codes and standards. The unit operates normally as intended by the manufacturer.	
Signature:	

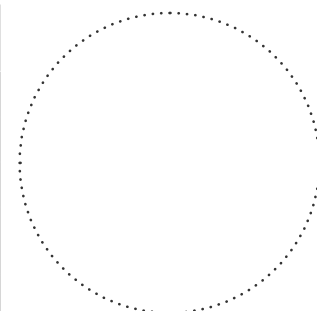

Installation Stamp

WARRANTY CARD

Unit Type	Electric axial fans
Model	
Serial Number	
Manufacture Date	
Purchase Date	
Warranty Period	
Seller	

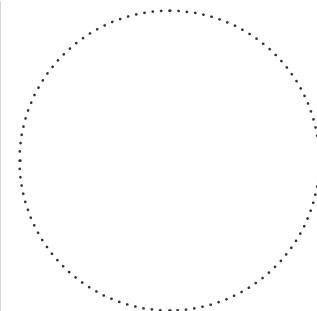

Seller's Stamp



Manufacturer: Ventilation Systems LLC,
Ukraine, Kyiv, 1 M. Kotsyubynskoho Street

Address of production facilities:
Ukraine, Kyiv Region, Fastiv District, Boyarka,
36 Sobornosti Street

